

6-150MAX



Carriers

20 - 30 ton Excavators
10 - 15 ton Loaders

Weight

1450kgs

Capacity

1.60m³

Flow

150 lpm

Screening Area

1030mm x 1500mm

Dimensions

A - 1030mm D - 1900mm

B - 1500mm E - 1830mm

C - 1240mm F - 1300mm

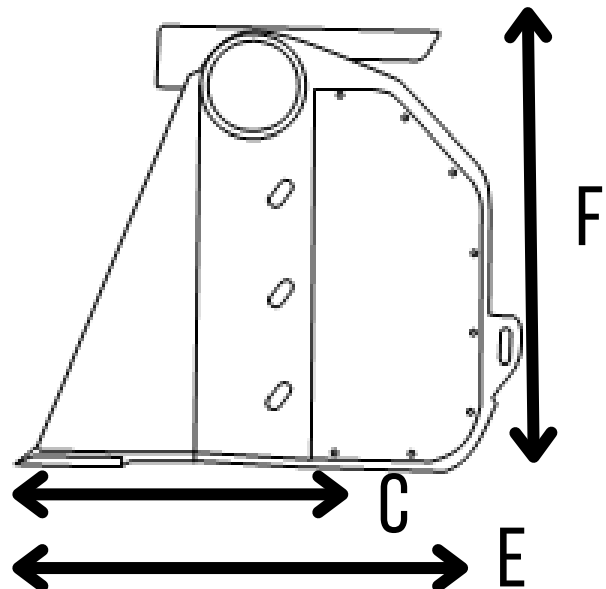
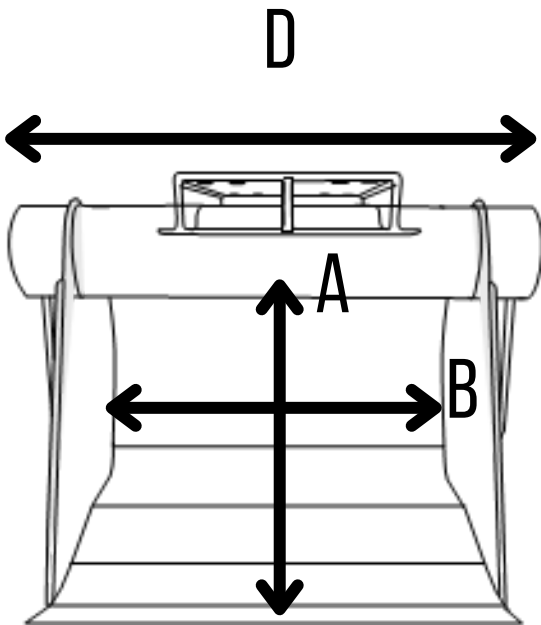

True Compact Screening
Low maintenance System
Poly-Stars screen without crushing
Non-stick floor as standard