

# 3-60E



## Carriers

2 - 4 ton Excavators

## Weight

240kgs

## Capacity

0.13m<sup>3</sup>

## Flow

55 lpm

## Screening Area

430mm x 560mm

## Dimensions

A - 430mm

D - 810mm

B - 560mm

E - 760mm

C - 530mm

F - 650mm

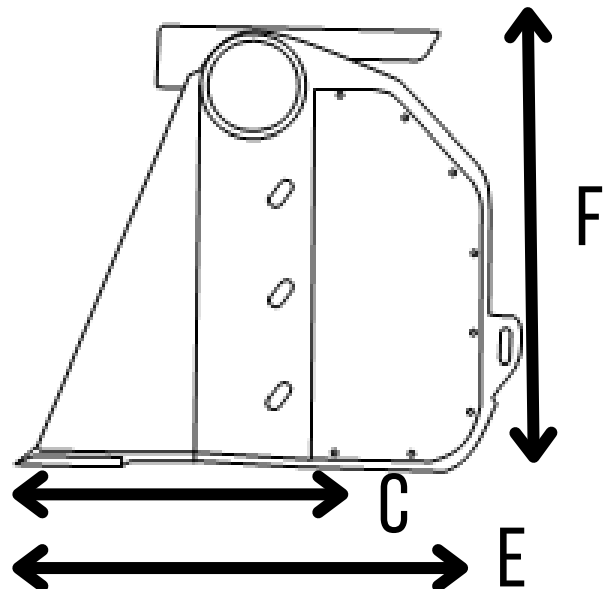
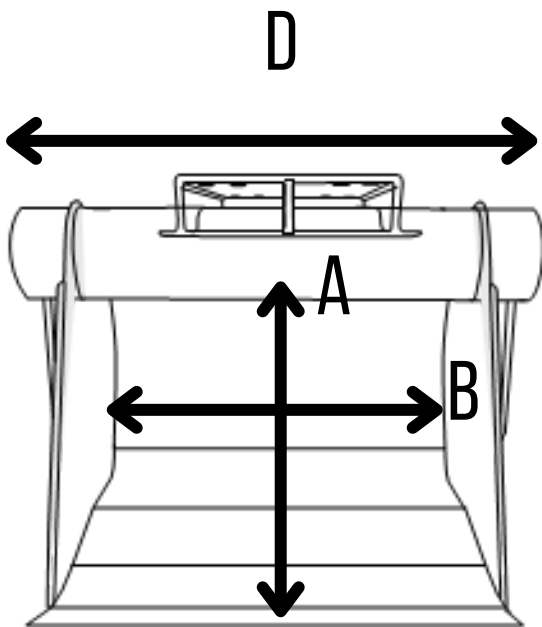

True Compact Screening  
Low maintenance System  
Poly-Stars screen without crushing  
Non-stick floor as standard