

# 3-80E

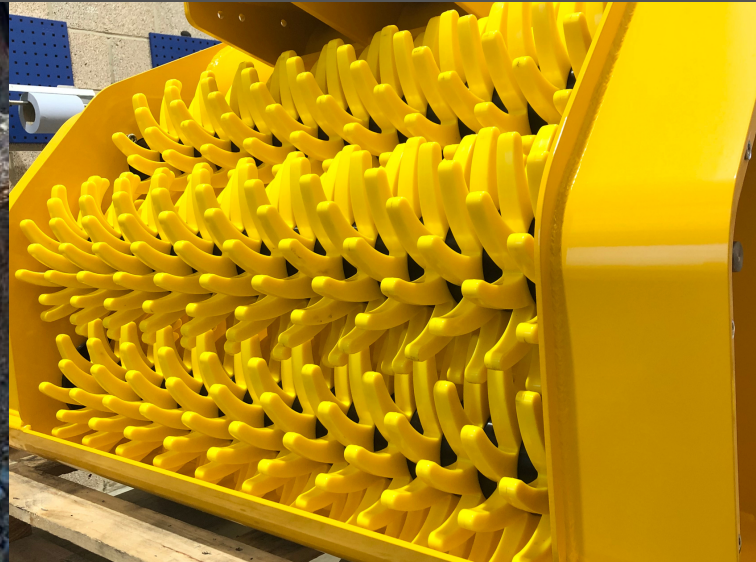

## Carriers

3 - 5 ton Excavators

## Weight

290kgs

## Capacity

0.18m<sup>3</sup>

## Flow

55 lpm

## Screening Area

430mm x 800mm

## Dimensions

A - 430mm

D - 1070mm

B - 800mm

E - 760mm

C - 530mm

F - 650mm

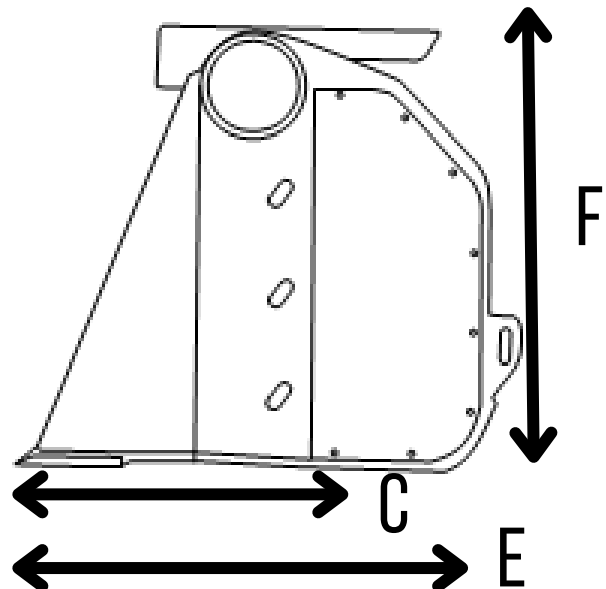
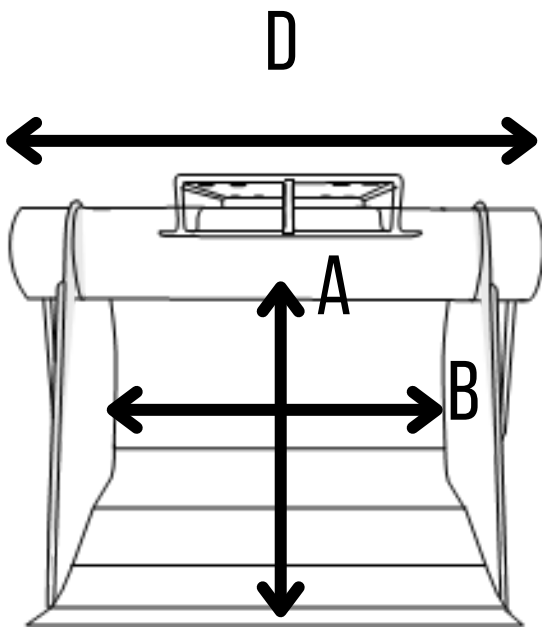

True Compact Screening  
Low maintenance System  
Poly-Stars screen without crushing  
Non-stick floor as standard