

3-150MAX



Carriers

7 - 10 ton Excavators
3 - 6 Loaders & Skid Steers

Weight

640kg

Capacity

0.55m³

Flow

70 lpm

Screening Area

430mm x 1500mm

Dimensions

A - 430mm D - 1790mm

B - 1500mm E - 1400mm

C - 500mm F - 720mm

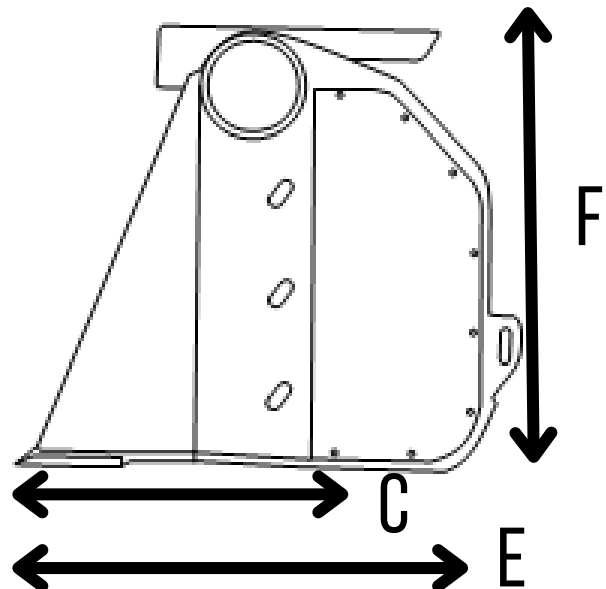
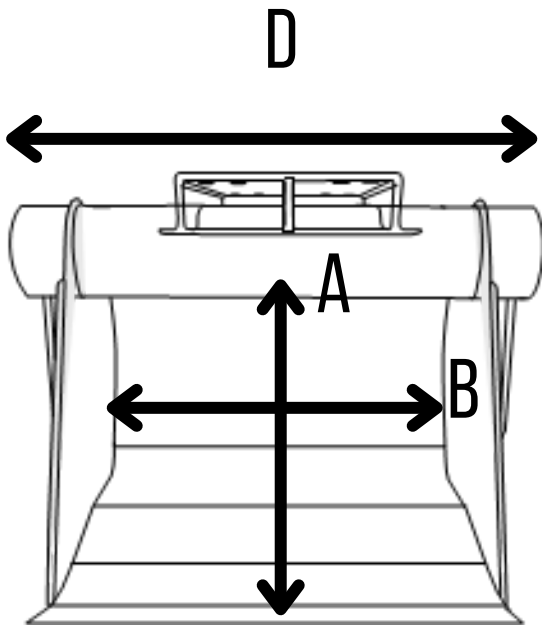

True Compact Screening
Low maintenance System
Poly-Stars screen without crushing
Non-stick floor as standard