

2-100L/SL



Carriers

1 ton Loaders

Weight

240kgs

Capacity

0.12m³

Flow

40lpm

Screening Area

300mm x 1000mm

Dimensions

A - 300mm

D - 1330mm

B - 1000mm

E - 590mm

C - 355mm

F - 510mm

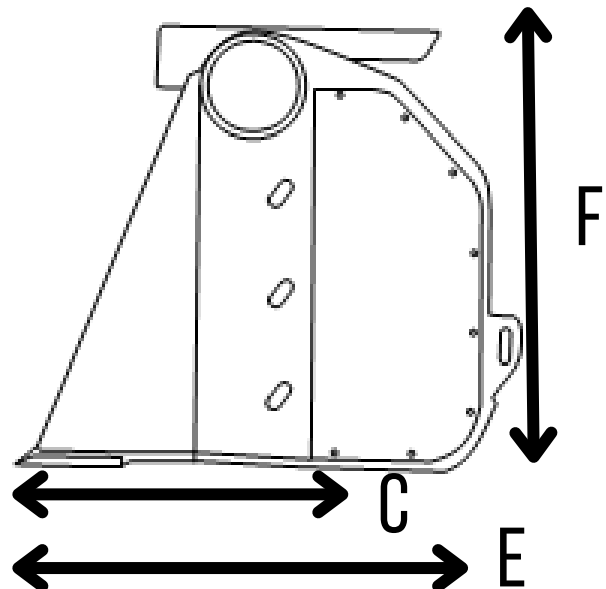
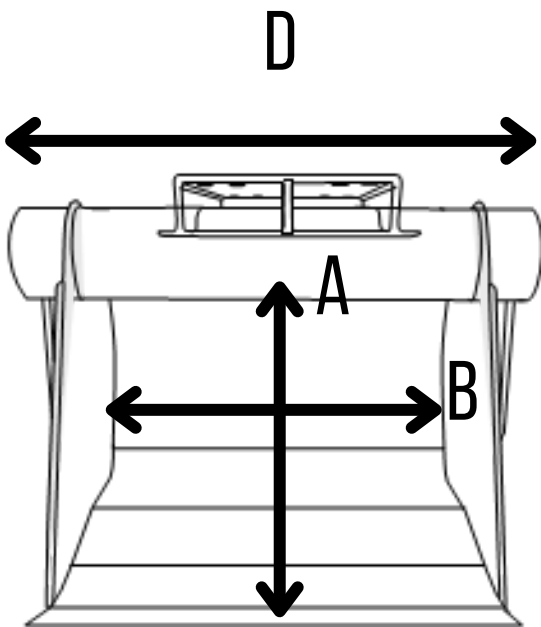

True Compact Screening
Low maintenance System
Poly-Stars screen without crushing
Non-stick floor as standard