

2-100E



Carriers

1.7 - 2.7 Ton Excavators

Weight

240kgs

Capacity

0.12m³

Flow

40lpm

Screening Area

300mm x 1000mm

Dimensions

A - 300mm D - 1300mm

B - 100mm E - 590mm

C - 355mm F - 510mm

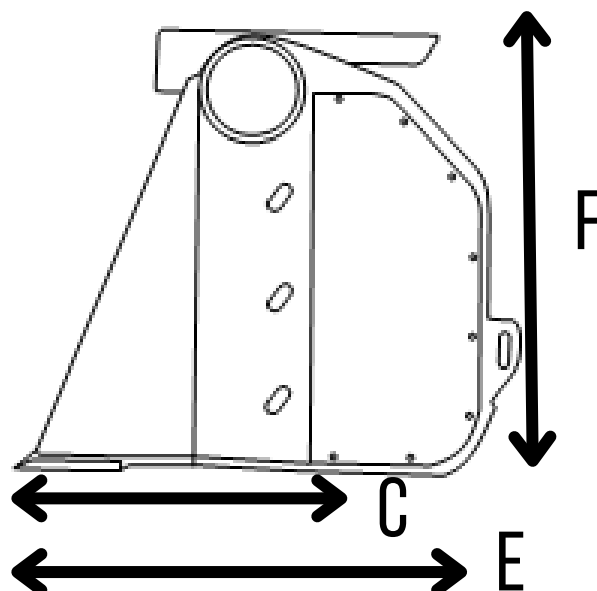
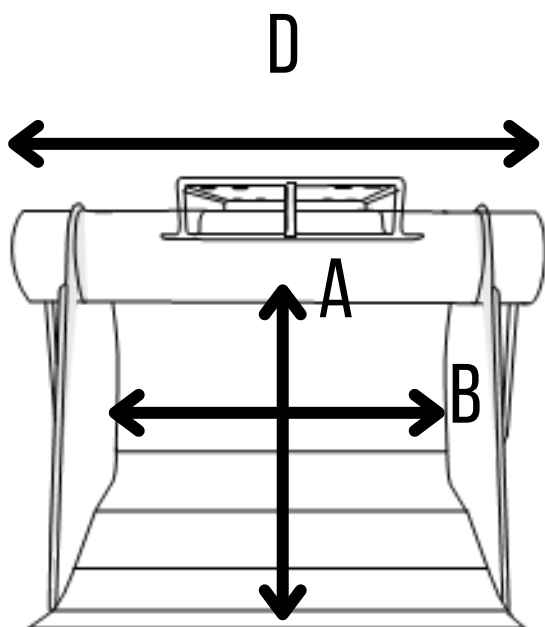

True Compact Screening
Low maintenance System
Poly-Stars screen without crushing
Non-stick floor as standard