

# 2-50E



## Carriers

1 - 2 Ton Excavators

## Weight

155kgs

## Capacity

0.06m<sup>3</sup>

## Flow

40lpm

## Screening Area

300mm x 480mm

## Dimensions

A - 300mm

D - 510mm

B - 480mm

E - 584mm

C - 355mm

F - 510mm

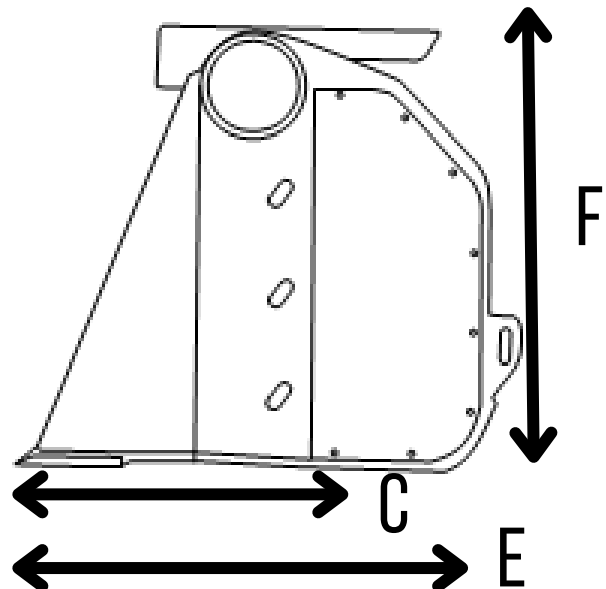
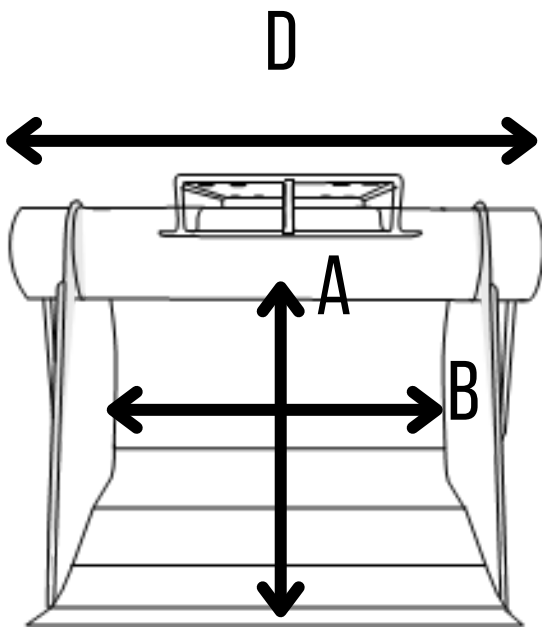

True Compact Screening  
Low maintenance System  
Poly-Stars screen without crushing  
Non-stick floor as standard