

5-150MAX



Carriers

16 - 24 ton Excavators
6 - 10 ton Loaders

Weight

1200kgs

Capacity

1.30m³

Flow

150 lpm

Screening Area

845mm x 1500mm

Dimensions

A - 615mm D - 1900mm

B - 1500mm E - 183mm

C - 1240mm F - 1060mm

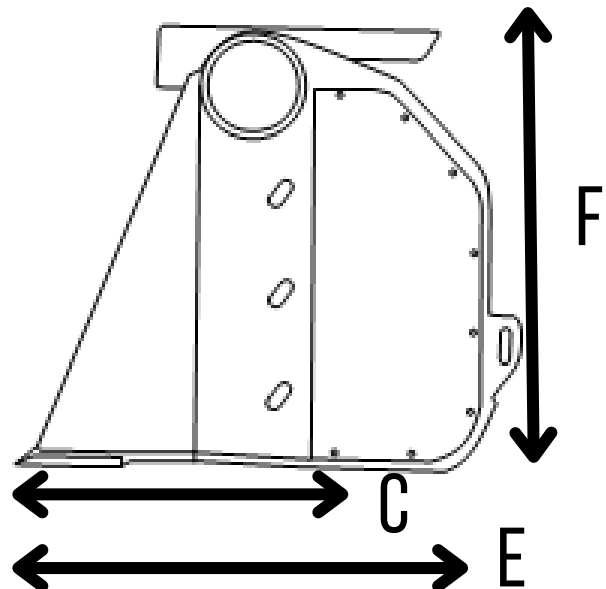
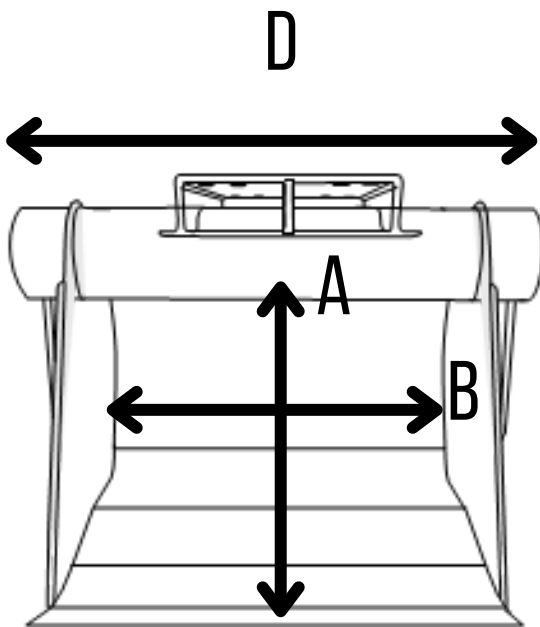

True Compact Screening
Low maintenance System
Poly-Stars screen without crushing
Non-stick floor as standard